

## INSTALLATION INSTRUCTION

<b>PRODUCT</b>	<b>AEROKLAS DRAW SYSTEM 1500 SERIES</b>
<b>MODEL</b>	<b>TOYOTA REVO (DOUBLE CAB)</b>

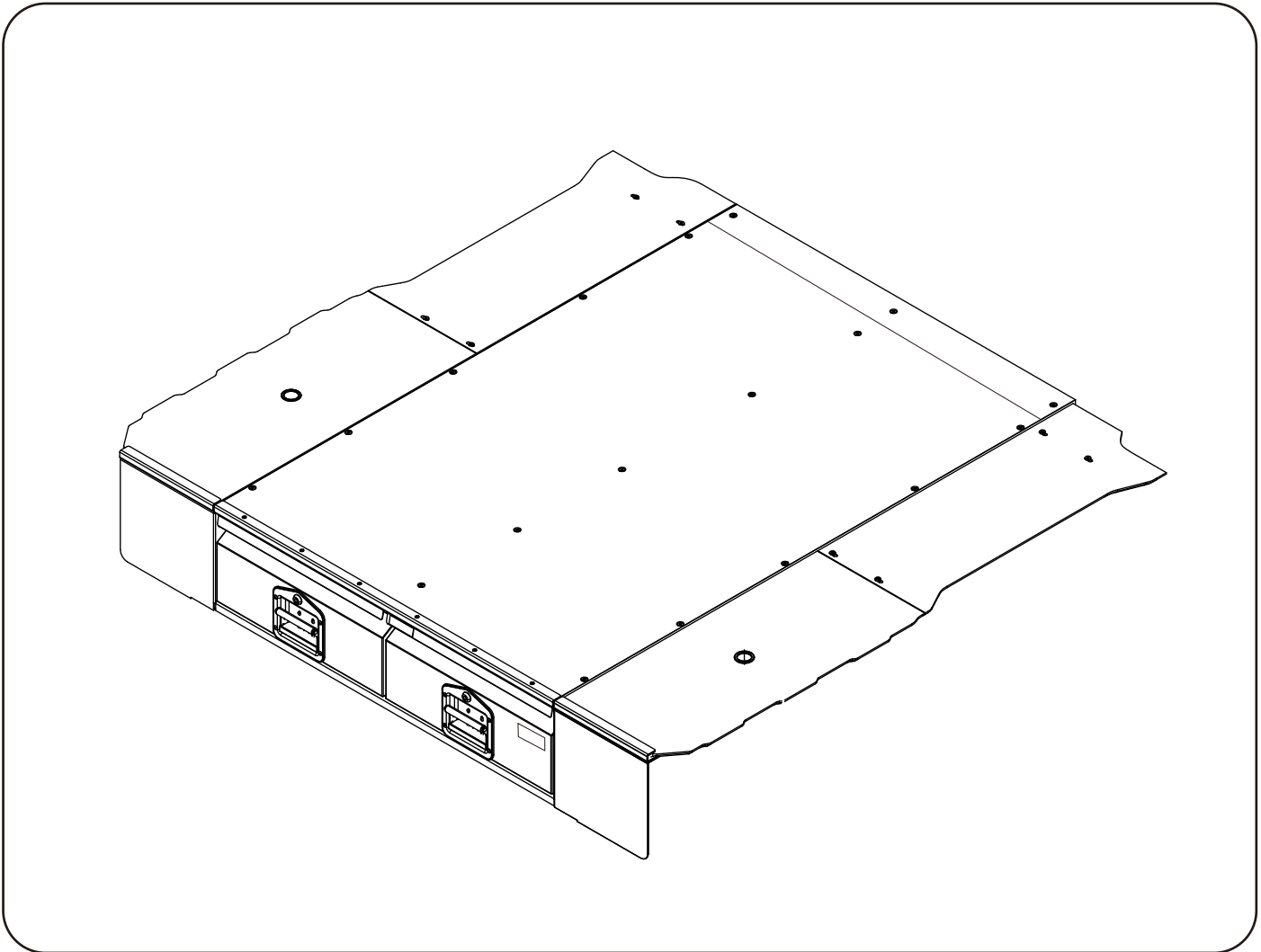

# PART LIST

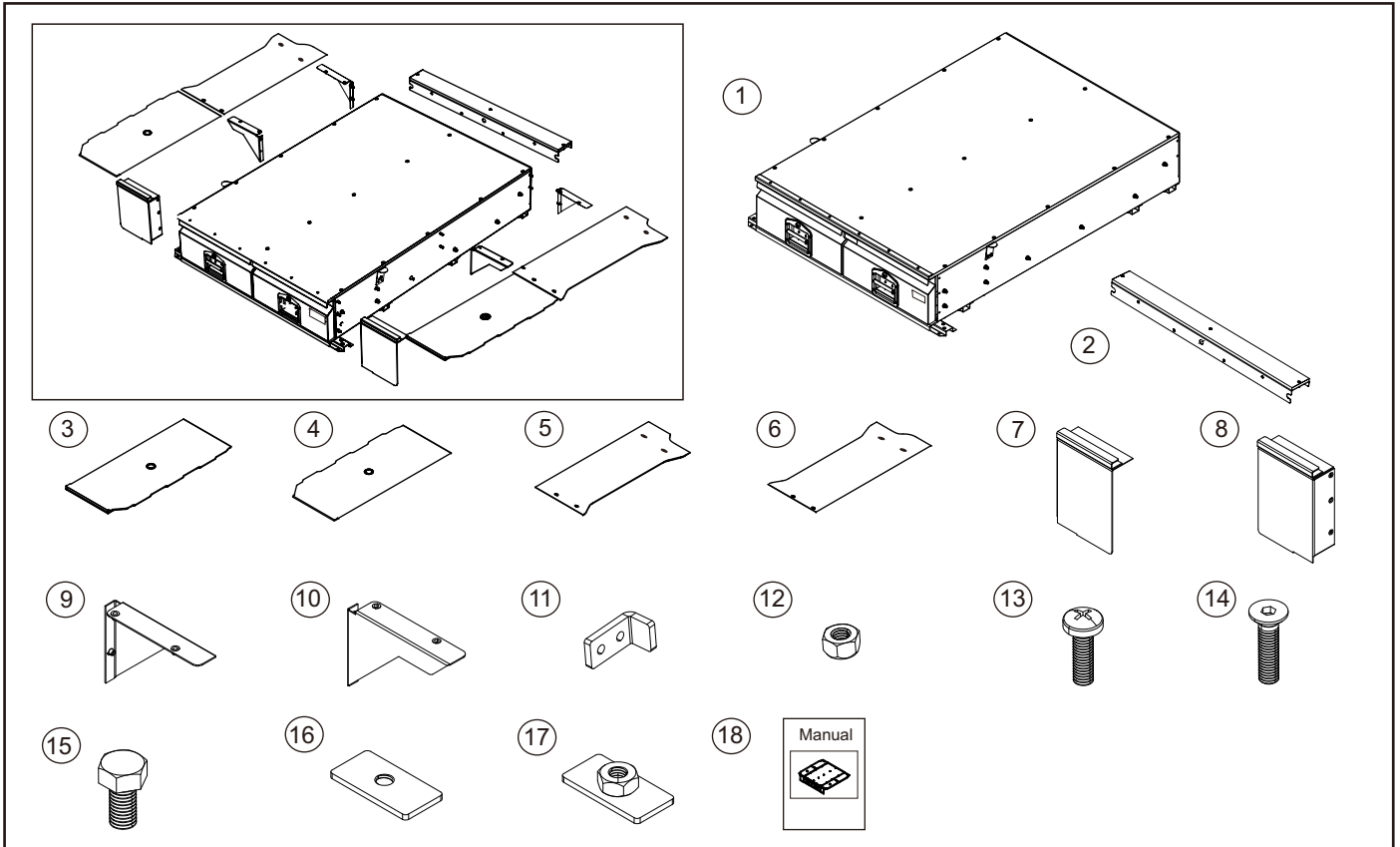

No.	Part Name	Q'ty
1.	AEROKLAS DRAW SYSTEM 1400 SERIES	1
2.	TOP PANEL L100 (SET)	1
3.	BW CONTOUR PANEL 1 X TOYOTA REVO	1
4.	BW CONTOUR PANEL 2 X TOYOTA REVO	1
5.	BW CONTOUR PANEL 3 X TOYOTA REVO	1
6.	BW CONTOUR PANEL 4 X TOYOTA REVO	1
7.	TM FASCIA (RH)	1
8.	TM FASCIA (LH)	1
9.	BW WING RIGHT 220	2
10.	BW WING LEFT 220	2
11.	BW CARGO PLATE MOUNTING TAB (STOPPER BRACKET)	4
12.	M6 NYLON LOCK NUT	8
13.	M6 X 20 MM PAN HEAD SCREW	30
14.	M6 X 30 MM CSK HEAD STAINLESS SCREW	8
15.	M10 X 25 MM HEX HEAD	4
16.	SUPPORT PLATE 25X50	4
17.	SUPPORT PLATE 25X50 (NUT)	4
18.	INSTALLATION MANUAL	1

## TOOLS

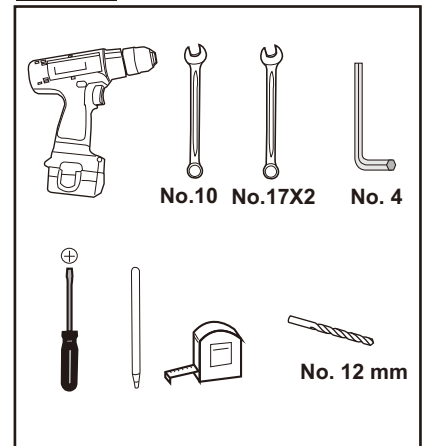

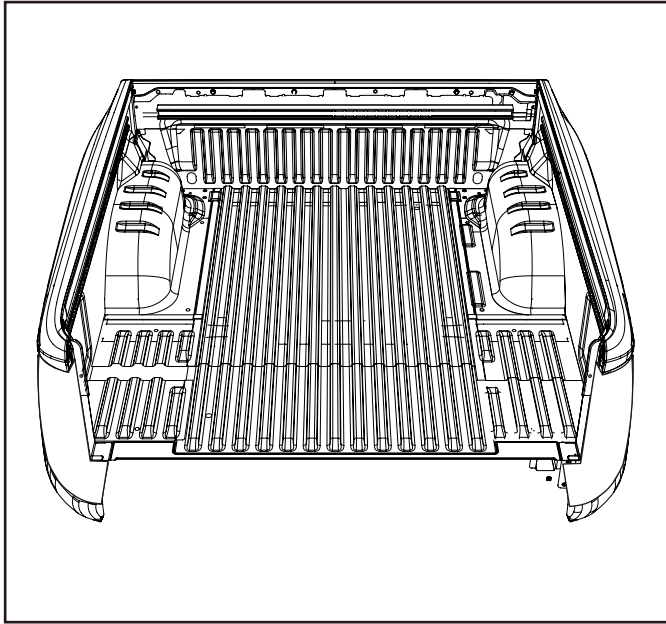

1. Prepare the vehicle for installation.
  - Remove and discard bed liner if fitted to the vehicle.
  - Remove 12V socket from the tub liner if fitted to the vehicle for re-installation using an accessory mounting bracket later (Supplied separately with installation instructions)

[ When removing power socket from liner ensure to keep the power socket cap and bolts for relocation ]

The spare wheel must be removed.

It is required to partially peel back the heat shield on the underside of the tub floor prior to drilling the floor for mounting plates.

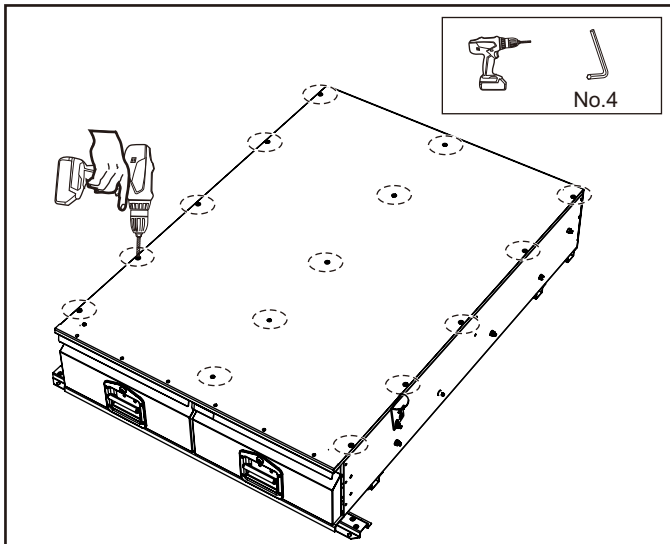

2. Prepare the drawer system for installation.
  - Remove the top panel assembly.

**DO NOT** remove the front alloy trim edge from the top panel assembly.

3. Carefully remove the draws fully from the frame and set aside.

**Note: TAKE CARE** the draw opening stopper brackets that prevent the draws from coming completely out IS NOT INSTALLED as delivered.

Also note which drawer came from which side (left and right)

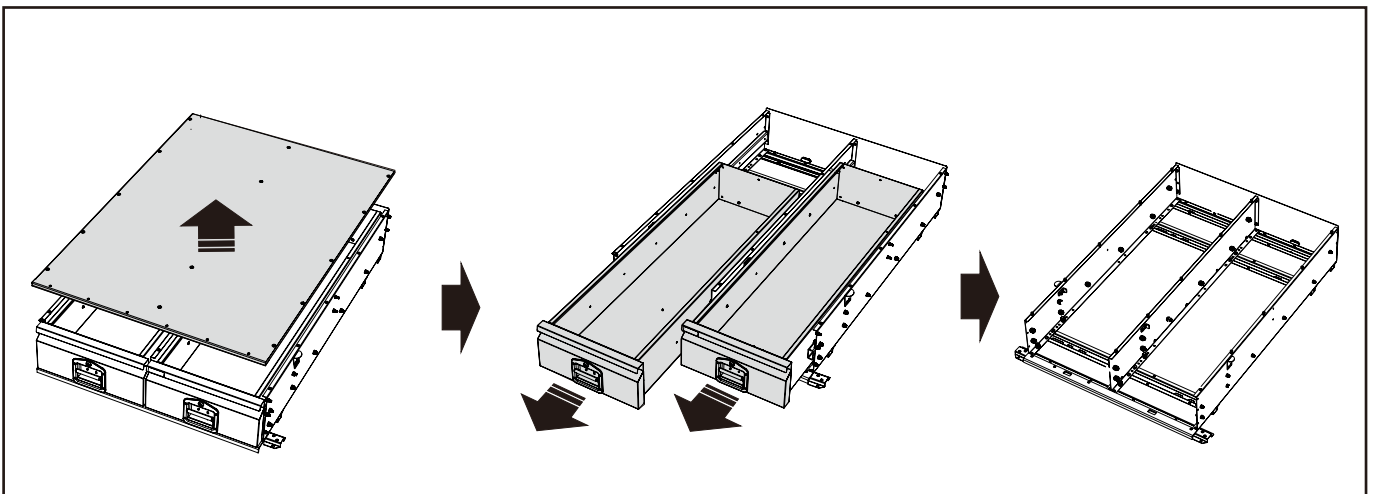

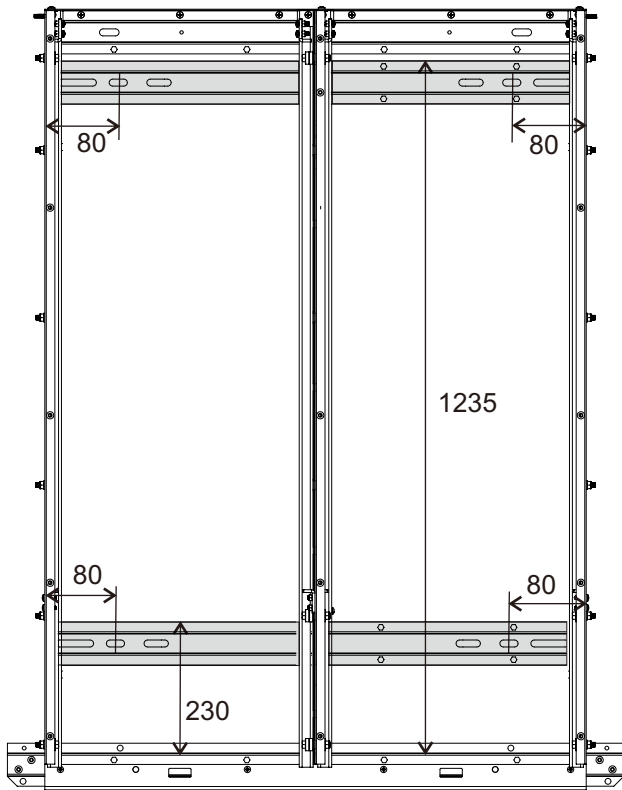

(Unit = mm.)

#### 4. Information only.

Assembly reference dimensions for the chassis.

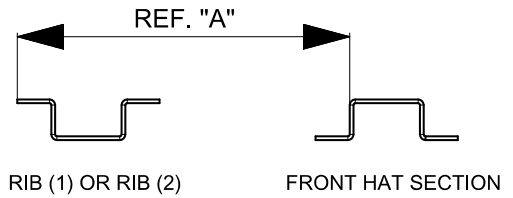
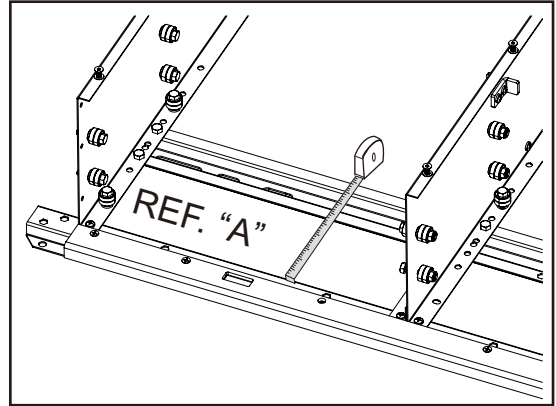

REF "A" is measured from the back face of front top hat section to the back of the rib (1) or rib (2) as show in picture and diagram above.

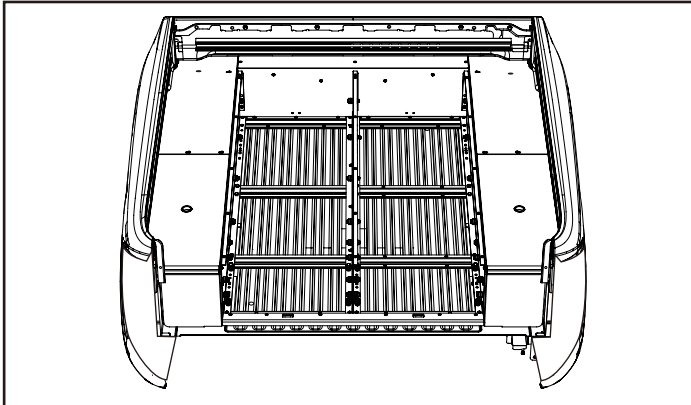

5. Place the chassis assembly in the vehicle and attach the top panel L100 (set) Item; ② using the M6x20 mm pan head screw ⑬. The front fascia panel brackets; items ⑦ & ⑧ using the M6 x 20 mm. pan head screw ⑬. Loosely fit the draw Wing Panel Brackets items; ⑨ & ⑩ using the M6 x 20 mm. pan head screw. Fit the contour panels items; ③, ④ and ⑤, ⑥ using the M6 x 30 mm. CSK head stainless screw ⑭ to confirm alignment to tub.

**Do not fully tighten any of these top panel & contour panel screws.**

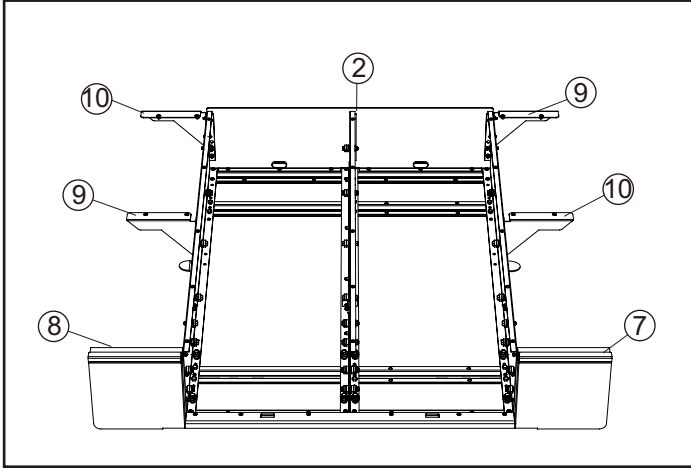

This step is critical to ensure that the unit is aligned & centralized in the tub against the contour panels, also ensure that the rear draw panel is square against tub headboard panel in the vehicle.

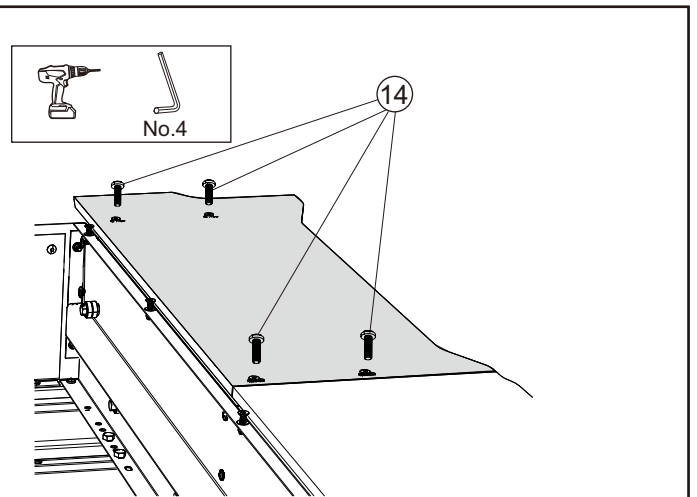
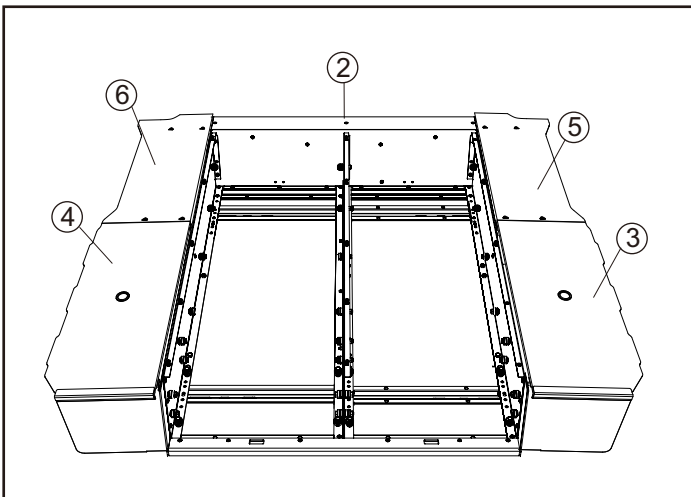
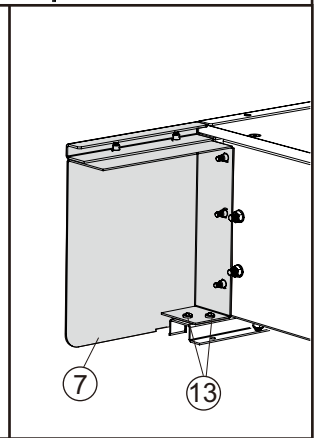
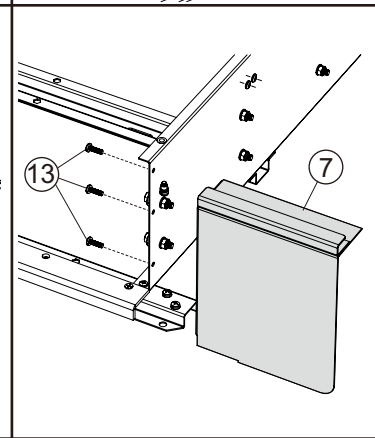
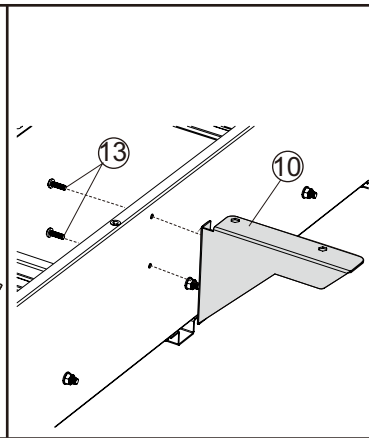
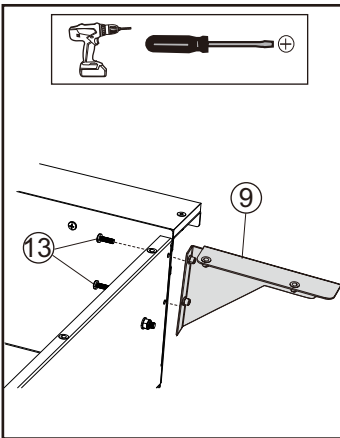
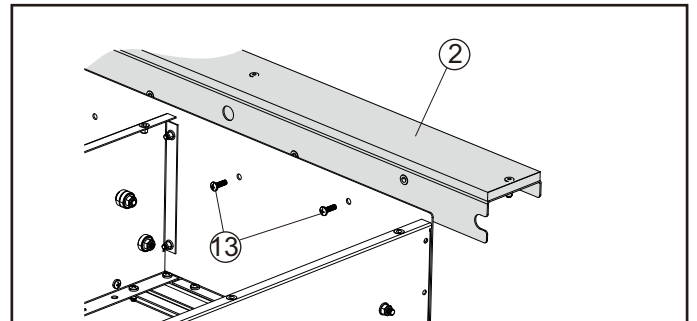

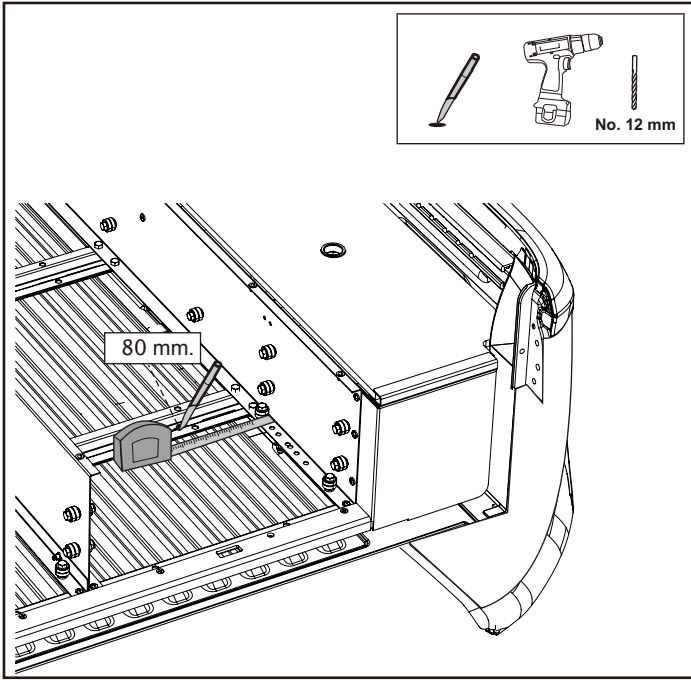

6. Measure (80 mm) & mark drilling 4 positions through Step 4. The drilling positions on the left and right sides should fall on the center of the tub peak ridges in the floor.

**If this is not the case, ensure the unit is central and the contour panels are aligned correctly BEFORE DRILLING. Drill using pilot hole then clear to 12 mm**

7. Vacuum any swarf left in the vehicle tub after drilling.

**Treat exposed surfaces of holes using brush on or spray on Cold Galvanizing Compound or rust preventative sealing paint**

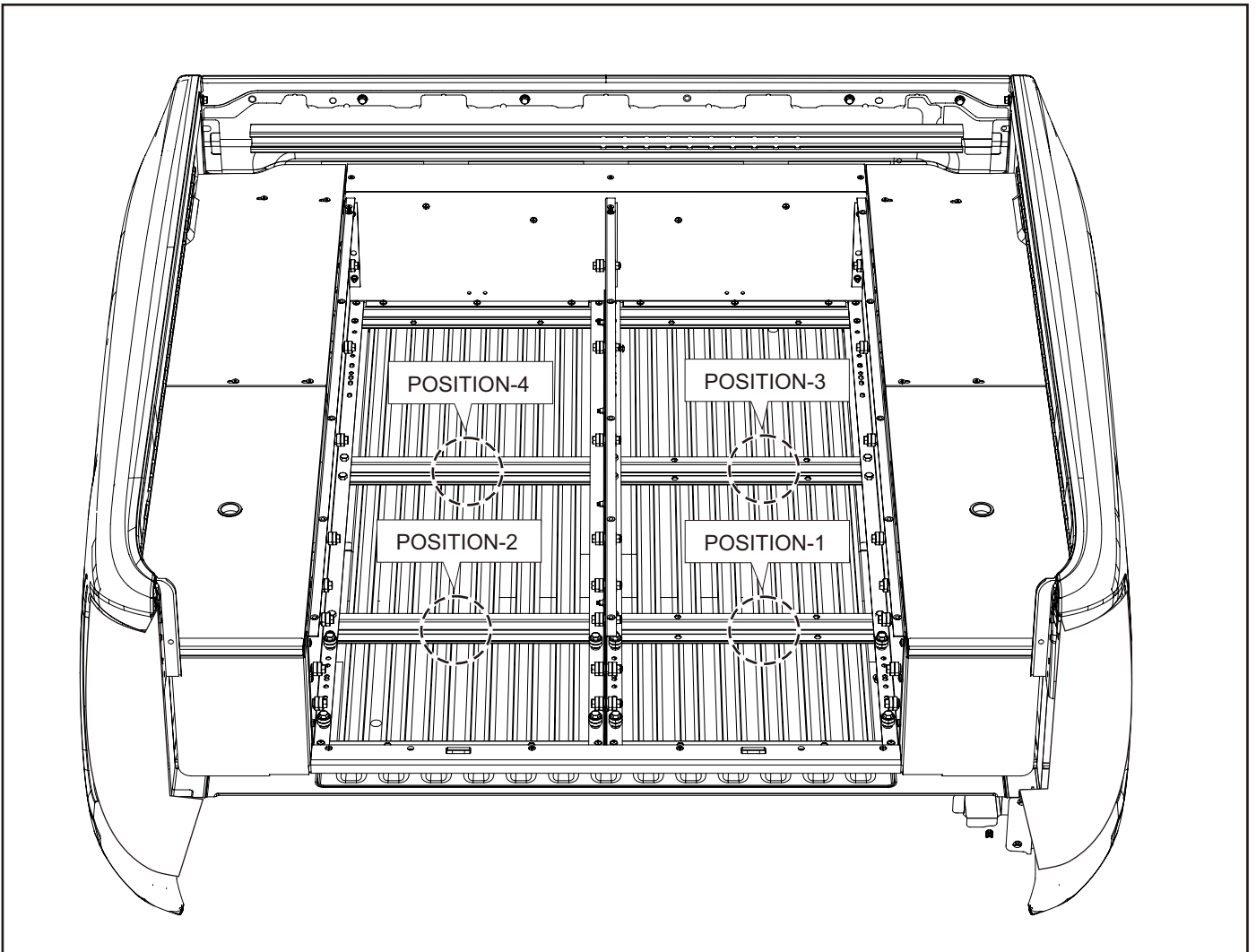

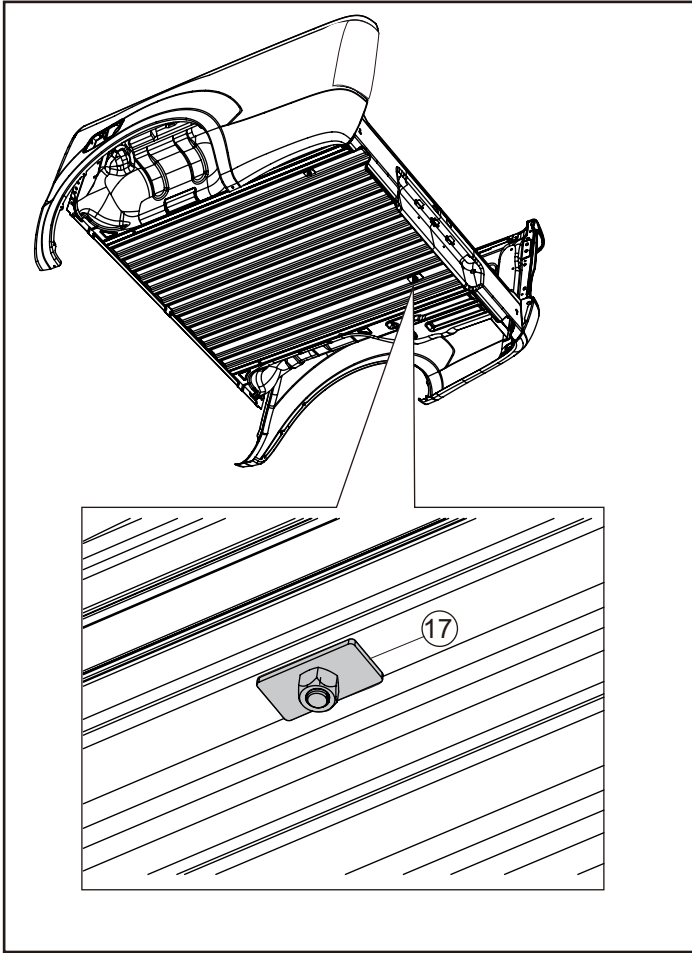

8. Fasten the unit to the vehicle using (15) M10 x 25 mm. Hex Head Set Screw with (16) support plate 25 x 50 fasten underneath using (17) support plate 25x50 (nut) in all positions as show.

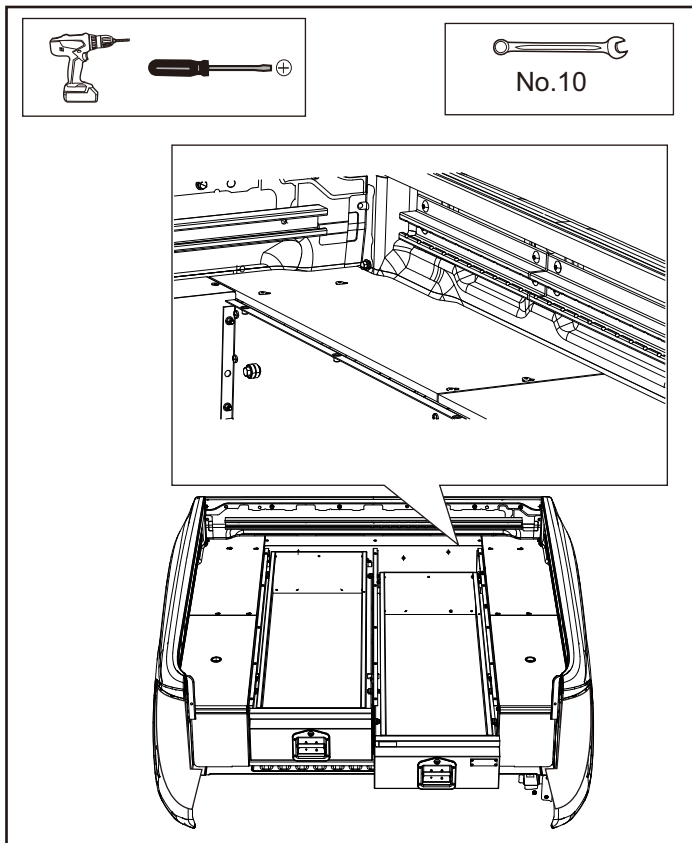
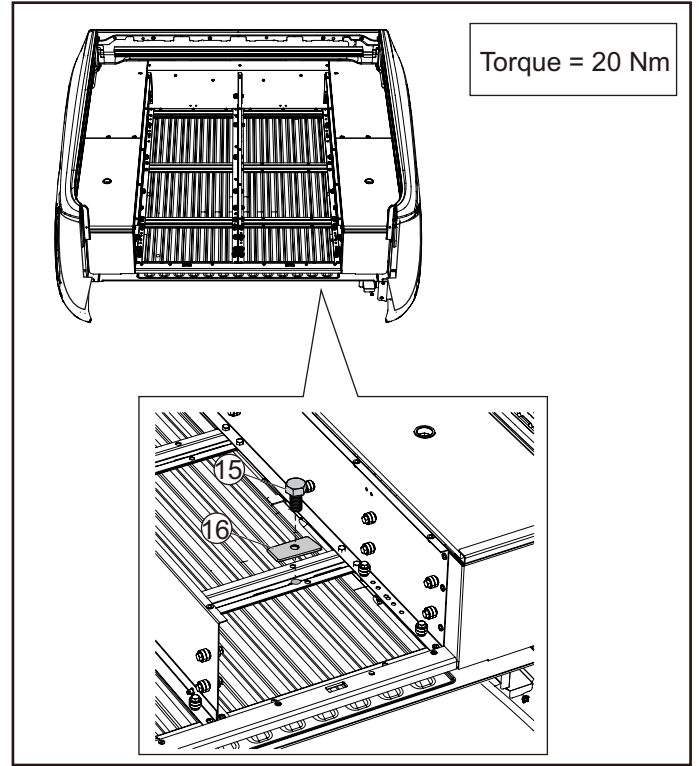

9. Reinstall the draws back into the chassis frame assembly as they were removed in Step 3 (left and right).

10. Install the draw side (11) cargo platemounting tab (stop brackets) 2 per draw positioned in the back left and right top corners that prevent the draws from falling out under normal use.

Fasten the stop brackets using (13) M6 x 20 mm. pan head screw to the inside of the drawer and (12) M6 nylon lock nut to the outside.

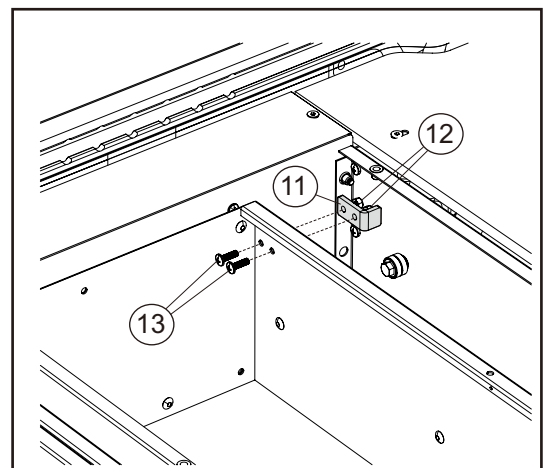

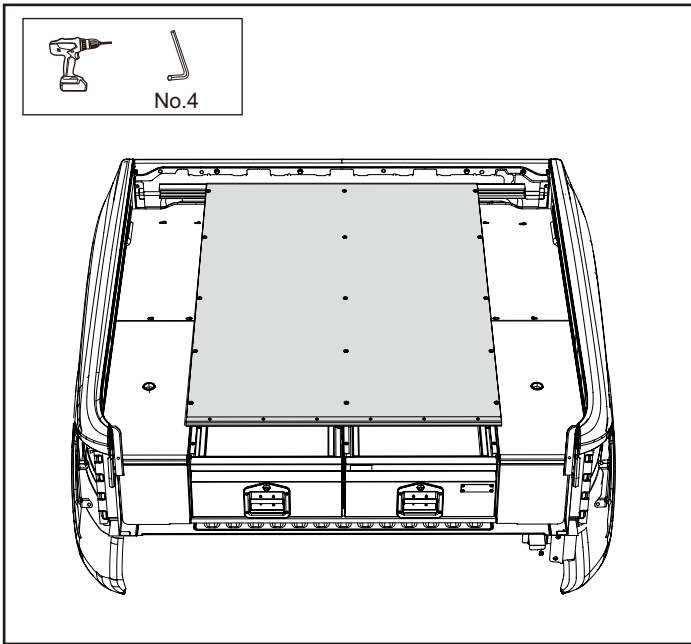

11. Re-attach the top panel and top ② assembly using the following tightening sequence shown. And fridges slide (if applicable).

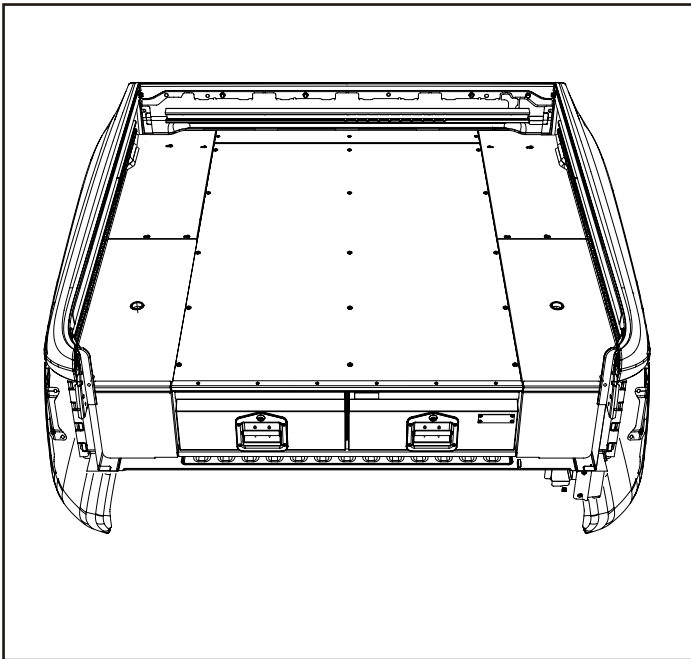

12. Check the draw system overall for smooth rolling of drawers, even gaps and any movement of drawers and slide functionality.